

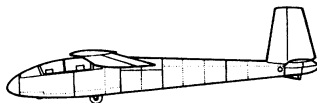

Aircraft Industries



MANDATORY BULLETIN

MB No: L13/116a

Concerns: All L13 Blanik sailplanes.

NOTE: Mandatory Bulletin No. L13/116a is not valid for the L-13A Blanik sailplanes type and the L-13 Blanik Reinforced sailplanes as defined in the MB No. L13/112a.

Subject: Check of the mechanical characteristics of the material the upper and lower spar cap.

Reason: Finding nonconforming mechanical characteristics of the material on the L13 Blanik sailplane in operation.

To be carried out at the latest by: Before further operation of sailplane.

To be performed by: Licence holder of aircraft maintenance according to ICAO, Annex 1 with L13 type qualification.
Organization / person authorized to test the conductivity of the materials using the eddy currents method.

Costs to be covered by: Operator.

Necessary material to be delivered by: Manufacturer.

Bulletin becomes effective: On the date of its issue.

Total No. of pages: 8

.....
Miroslav Pešák
Chief Designer

The technical content of this document is approved under the authority of DOA Nr. EASA.21J.119.

January 24, 2013

A. WORK PROCEDURE

1. Remove the LH and RH wing from the sailplane.
Put the removed wings into the vertical position into the racks prepared beforehand
- see fig. 3.
2. Perform the following procedures for assurance of access to check points:
 - a. Disconnect the aileron control rod from the lever at the rib No. 1, remove the overbridging. Put the aileron control rod on the main spar.
 - b. Pull the wing flaps to the max. extended position and secure the position with the suitable pads between the flaps leading edge and wing trailing edge - refer to the fig. 3.
Disconnect the wing flaps control rod at the rib No. 1 of wing flap, remove the overbridging. Fix the drive shaft of the wing and brake flaps using the binding wire - refer to the fig. 3.
Remove the auxiliary support, located on the wing rib No. 1
(Drill off the 2 pc rivets, or 1 pc rivet and turn the auxiliary support down).
3. Through a access hole, perform the check of the mechanical characteristics of the material the upper and lower spar cap as follows:
 - a. Before the check, clean the dirt and grease from the controlled space, using appropriate preparations.
For check is accessible the vertical part of the spar cap, adjacent to the spar - refer to the fig. 2.
Carry out the check in the areas described on the fig. 2.
 - b. Check method: test the conductivity of the materials using the eddy currents
 - Recommended measurement frequency: 60 kHz
 - Probe diameter: not exceeding 14 mm
 - Measuring contact points: upper and lower spar cap (between rivets) - refer to the fig. 2.
 - c. Permissible range of measured value

% IACS (International Annealed Copper Standard)
28.5 - 34.0
 - d. Repeat the measurements several times for verify the results, in the several areas described on the fig. 2.
 - e. Any other measuring method must be approved by the sailplane manufacturer before it can be used.

4. If the values measured during the check are within the permissible limits specified make a record in the sailplane logbook (see section I of this Bulletin) and inform the manufacturer of the sailplane as instructed in Section A, item 5 of this Bulletin.
5. If the values measured during the check are not within the permissible limits, make a record in the sailplane logbook (see section I of this Bulletin) and inform the manufacturer of the sailplane.

Report to manufacturer must include following information:

- measured values (% IACS) for the LH and RH wing,
- sailplane Serial Number,
- sailplane Registration Mark,
- serial number of LH and RH wing,
- total numbers of flight hours,
- number of landings

Contact Address: Aircraft Industries, a. s.
Product Support Department
Kunovice 1177
CZ 686 04
phone: +420 572 817 660,
fax: +420 572 816 112
e-mail: ots@let.cz

6. After check, install back the aileron control rod and flap control rod:

NOTE: All bolts must be fitted with the head up (in position corresponding to horizontal flight).

- a. Remove the fixing of the drive shaft of the wing and brake flaps. Connect the disconnected control rods. Use the new cotter pins for securing the nuts. Rivet back the auxiliary support, which located on the rib No. 1 on the wing.
- b. Install the disconnected overbridging according to the Manual for Operation and Maintenance of the L13 Blanik Sailplane without overhaul.
- c. Install LH and RH wing on the sailplane.

B. MATERIAL REQUIRED

1.6 x 16 CSN 021781.04 Cotter pin – Order No. 36101616 – 4 pcs

2.6x8 Rivet – Order No. 35232608 – 4 pcs (for auxiliary support)

C. ILLUSTRATED PART

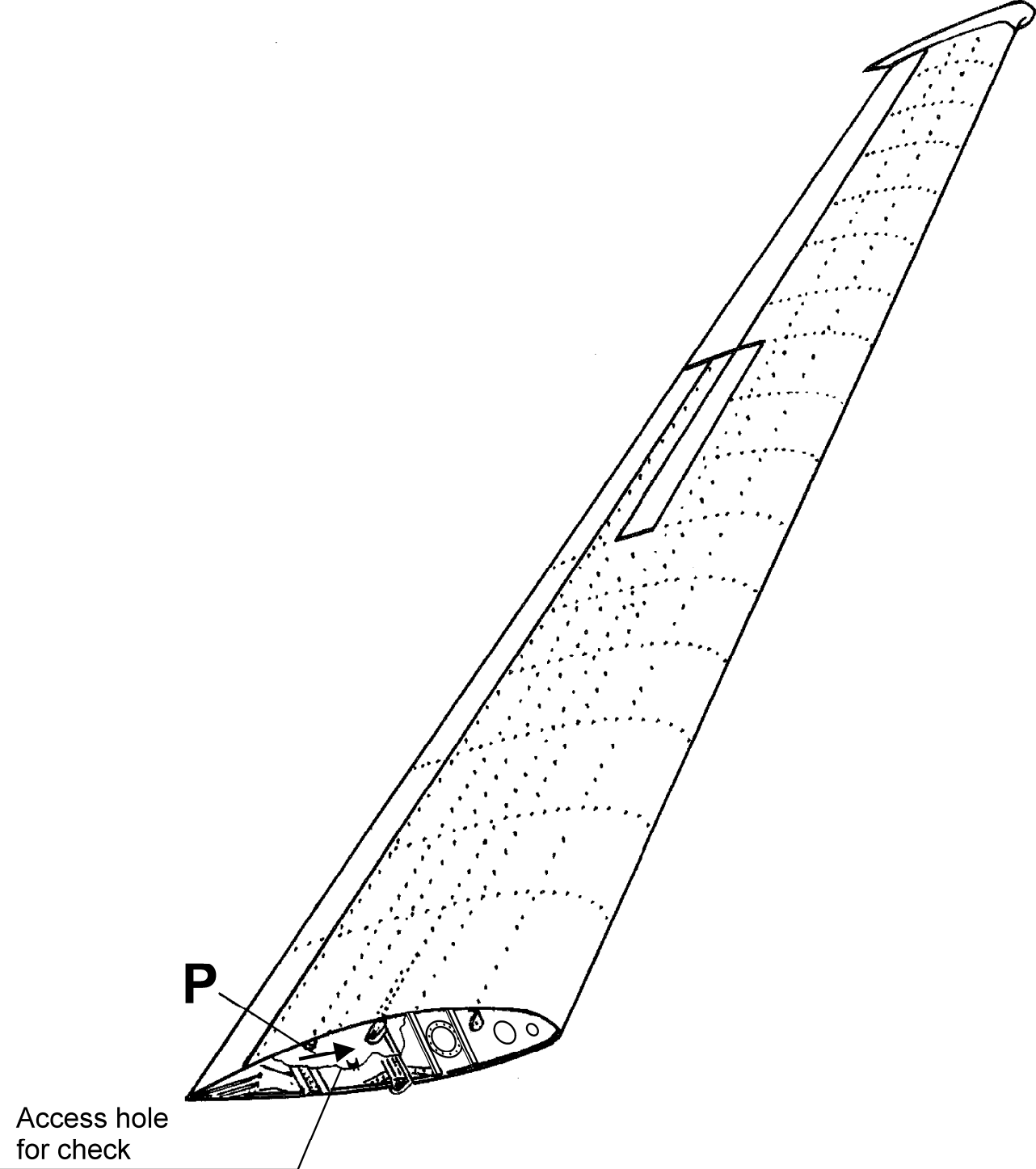

Fig. 1

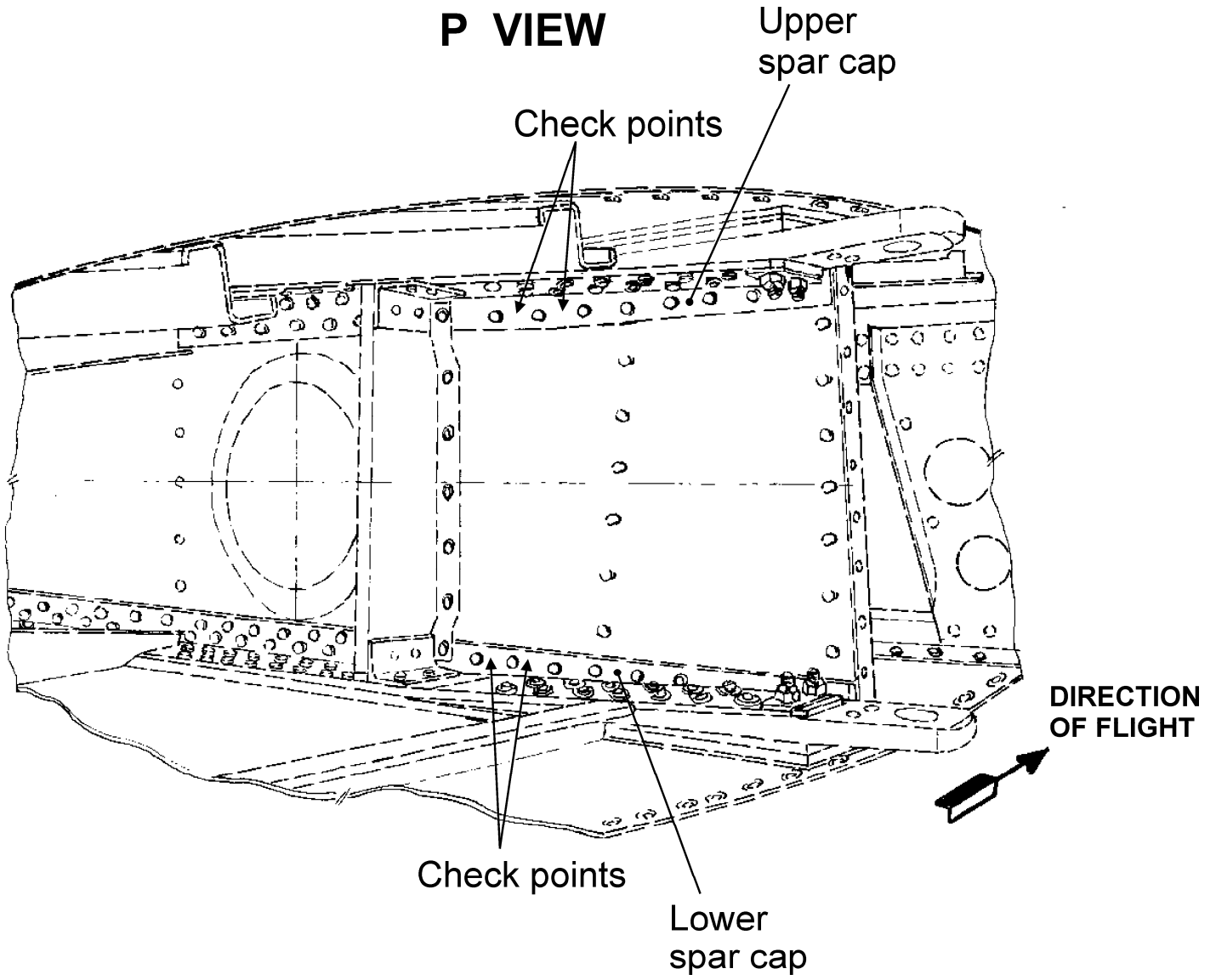

Fig. 2 - Check points on the upper and lower spar cap

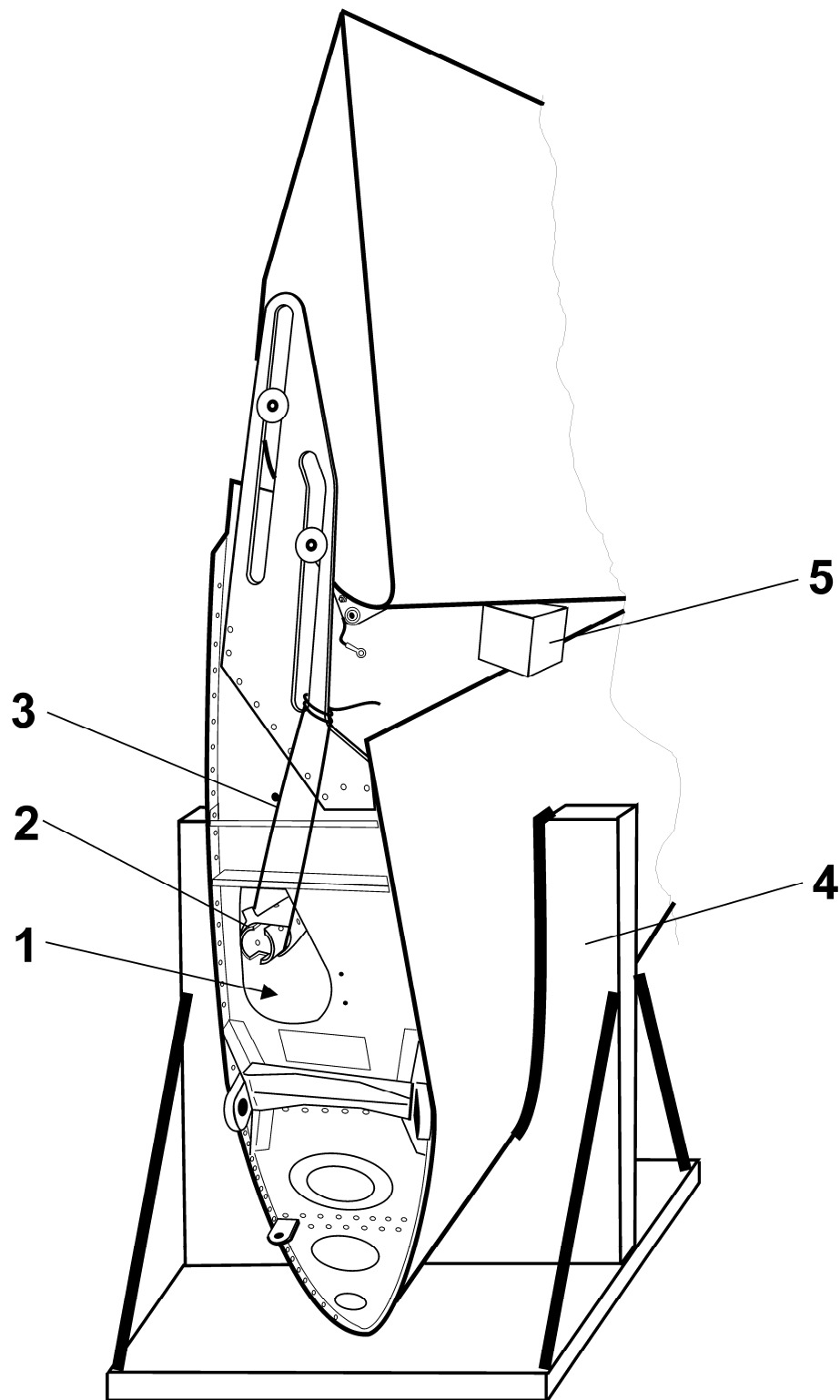

Fig. 3 - View of the prepared wing on the check

- (1) Access to the check;
- (2) Drive shaft of wing and brake flaps in wing;
- (3) Binding wire;
- (4) Suitable rack;
- (5) Suitable pads

D. DOCUMENTATION REQUIRED

Manual for Operation and Maintenance of the L13 Blanik Sailplane without overhaul,
Document No. Do-L13-1131.3

E. MAN-HOURS

Supposed man-hours for remove and montage work procedures: about 3m-hrs.

Supposed man-hours for check procedure: about 1m-hrs.

F. TOOLS REQUIRED

a. Material hardness testing device:

- Eddy current conductivity tester

(Device for the check the conductivity of aluminum alloys must be able to measure the conductivity with an accuracy of +/- 1% IACS or better. The device must have a sensitivity (resolution) 0.5% IACS or better in certified conductivity range.)

b. Standard equipment authorized service center.

G. SPARE PARTS IN OPERATION

The spare parts in stock, if any, must be tested as instructed in Section A, item 3 of this Bulletin.

H. SAILPLANE MASS

Not affected.

I. RECORD IN AIRFRAME LOGBOOK AFTER BULLETIN IMPLEMENTATION

Check of the mechanical characteristics of the material the upper and lower spar cap has been performed according to the MB L13/116a.

Found status:

Measured values (%IACS):

A. LH wing - lower spar cap ; - upper spar cap

B. RH wing - lower spar cap ; - upper spar cap

Material is conforming / nonconforming of permissible limits measured values.

In any event, send the report to the manufacturer of sailplane as instructed in Section A, item 5 of this Bulletin.

If the values measured during the check are nonconforming of permissible limits sailplane must not be released to operation.

Date:

Carried out by:
(legible signature of authorized worker)